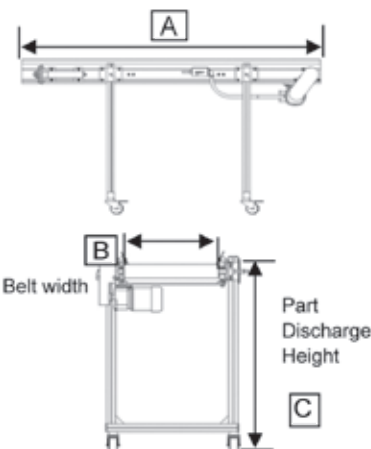
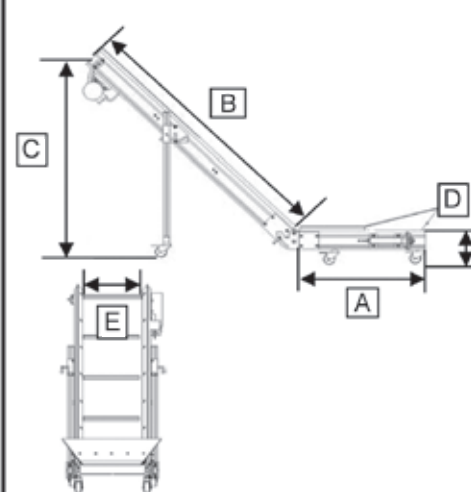
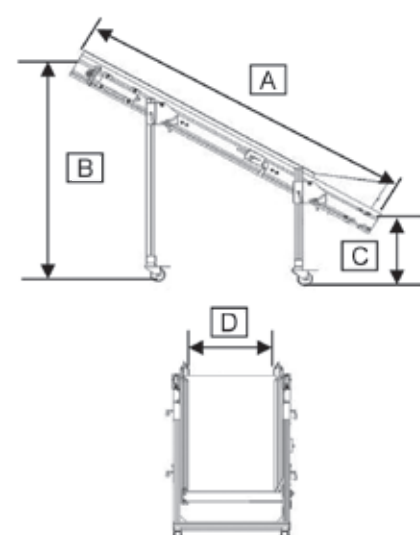

IMS Custom Conveyors

Select Type:

<p>Horizontal <input type="checkbox"/></p> <p>Style: Flat top <input type="checkbox"/> (select one) 3" Std side rails <input type="checkbox"/> Other (specify) <input type="checkbox"/></p>  <p>Overall Length (A) _____</p> <p>Belt Width (B) _____</p> <p>Height (C) _____</p>	<p>Horizontal to Incline <input type="checkbox"/></p>  <p>Horizontal Length (A) _____</p> <p>Incline Length (B) _____</p> <p>Discharge Height (C) _____</p> <p>Infeed Height (D) _____</p> <p>Belt Width (E) _____</p>	<p>Incline <input type="checkbox"/></p>  <p>Overall Length (A) _____</p> <p>Discharge Height (B) _____</p> <p>Infeed Height (C) _____</p> <p>Belt Width (D) _____</p>
---	---	---

Belt - (Standard Lacing)
 Optional - Seamless Belt
 Select one:

Color Green Black
 White Other

Other color specify : _____

Temperature / Type of Material Conveyed : _____

Cleats - Yes No
 Std Cleat Height is 1.5" : other _____
 Cleats spacing 18" Standard
 Other than standard - _____
 Cleat spacing required : _____

Note:
 If overall width of conveyor is critical, please specify max width dimension:

Motor - (check one)
 Std - 19 fpm
 Variable speed - 0-27.5 fpm
 Other - _____

Options - (check one or more)
 Indexing - Specify Part deflector at discharge end
 Reversing Photoelectric eye
 Heavy Duty Slider Bed (to withstand heavier part loads over 60# per sq foot)

Motor Position -

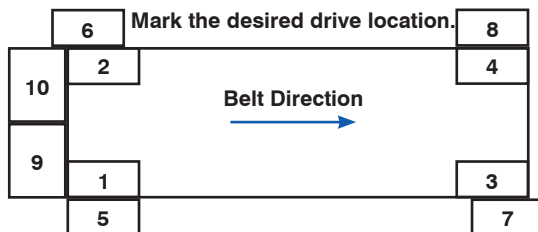

- 1, 2, 3, 4 - Mounted underneath. (standard)
- 5, 6, 7, 8 - Mounted on side. (up-charge)
- 9, 10 - Mounted on end. (up-charge)

Injection Machine -

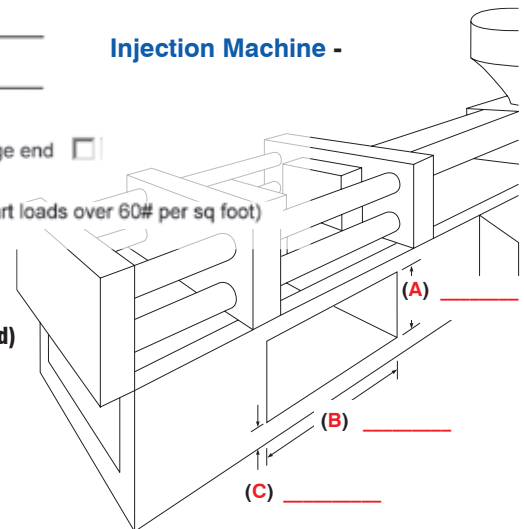

Date: _____ Quantity: _____ Phone: (_____) _____ Fax: (_____) _____

Name: _____ Title: _____

Company Name: _____ Email: _____

Address: _____

City: _____ State: _____ Zip: _____